

**802.11b/g/n WLAN/BT Front-End Module**

**Block Diagram**

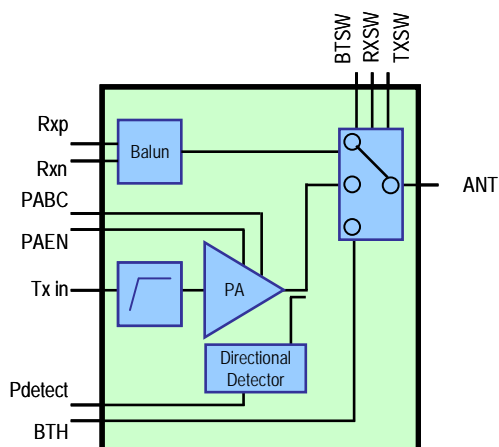

**Product Description**

The TQM679002A is full WLAN/BT front-end module in an ultra small 3mm x 3mm footprint package for 802.11b/g/n and Bluetooth applications. The TQM679002A contains 2.4GHz PA, directional detector, front-end switch, Bluetooth path and receive balun. The architecture and interface are optimized for next generation WLAN integration into handset devices. The front-end module features CMOS compatible control voltages to facilitate ease of use. With its low power dissipation, the front-end Module contributes to the extended battery life of next generation WLAN solutions. The front-end module is manufactured in TriQuint's high-reliability E/D pHEMT technology and is assembled in thin profile 3mm x 3mm x 0.45mm ETSLP - 16 Pb-Free package.

**Electrical Specifications**

Parameter	Min	Typ	Max	Units
Frequency	2400		2500	MHz
Pout, 802.11g, 64QAM		17		dBm
EVM		3.5		%
Current, 802.11g, Pout=15.5dBm		113		mA

Note 1: 3.6V supply, +25°C

Data Sheet: Subject to change without notice

For additional information and latest specifications, see our website: [www.triquint.com](http://www.triquint.com)

**Features**

- Fully Integrated, 802.11b/g/n + BT front-end module
- Internally matched input/output
- Integrated directional detector
- Temperature Compensated Bias Network
- Single battery voltage of 2.3V-5.5V
- Leadless 3.0 x 3.0 x 0.45 mm SMT Pb-Free
- Pout = 20.5dBm 802.11b and 16dBm OFDM 64QAM at 3% EVM

**Applications**

- IEEE802.11b/g/n WLAN/BT Applications
- Single-Chip RF Front-end Module
- Wireless LAN Systems
- Portable Battery-Powered Equipment

**Package Style**

- 3.0x3.0x0.45mm ETSLP Plastic Package



## 802.11b/g/n WLAN/BT Front-End Module

### Absolute Maximum Ratings

Symbol	Parameter	Absolute Maximum Value	Units
$V_{B1}, V_{B2}, V_{B3}$	Power Supply Voltage, no RF Applied	-0.5 to 6.0	VDC
$P_{INPUT}$	Maximum TX Input Power	10	dBm
$P_{DISS}$	Power Dissipation	3	W
$T_C$	Case Temperature, Survival	-40 to +100	°C
$T_{STG}$	Storage Temperature	-40 to +150	°C

Note: The part may not survive all maximums applied simultaneously.

### General Characteristics (Supply Voltage, Leakage Currents, Ambient Temp. ESD, etc...)

Symbol	Parameter	Min	Typ/Nom	Max	Units
$V_{B1}, V_{B2}, V_{B3}$	Supply Voltage	2.3	3.6	4.8	VDC
$V_{B1}, V_{B2}, V_{B3}$	Supply Voltage (Maximum Operating Condition)			5.5	VDC
$V_{B1}, V_{B2}, V_{B3}$	Supply voltage ripple with no degradation			500	mVp-p
$V_{B1}, V_{B2}, V_{B3}$	Supply voltage ripple with degraded performance			900	mVp-p
$I_{LKG}$	Leakage current single-band ( $T < 25°C$ )			30	uA
$T_{AMB}$	Ambient Temperature (Degraded Performance)	-40		-30	°C
$T_{AMB}$	Ambient Temperature (No Degradation)	-30		+75	°C
$T_{AMB}$	Ambient Temperature (Degraded Performance)	+75		+85	°C
$ESD_{HBM}$	Human Body Model (HBM) – all pins (EIA/JESD22-A114)			JEDEC Class 1B	
$ESD_{CDM}$	Charge Device Model (CDM) – all pins (EIA/JESD22-C101)			JEDEC Class IV	
$V_{IH}$	Digital control lines HIGH	1.58		2.0	V
$V_{IL}$	Digital control lines LOW	0.0		0.01	V

Data Sheet: Subject to change without notice

For additional information and latest specifications, see our website: [www.triquint.com](http://www.triquint.com)



## 802.11b/g/n WLAN/BT Front-End Module

### Electrical Characteristics<sup>1,2,3</sup>

Parameter	Conditions	Min.	Typ/Nom	Max.	Units
RF Frequency		2400		2500	MHz
Output Power	802.11n MCS7 (@2.7-4.8Vbatt, -30C to +75C), EVM < 2.8%	14.5	16.0		dBm
EVM	802.11n MCS7 (@2.7-4.8Vbatt, -30C to +75C)		2	2.8	%
Current	802.11n MCS7 (@2.7-4.8Vbatt), Pout=15.5dBm min.		110		mA
Output Power	802.11g QAM64 (@2.7-4.8Vbatt, -30C to +75C), EVM < 3.5%	15.5	17		dBm
EVM	802.11g QAM64 (@2.7-4.8Vbatt, -30C to +75C)		2.2	3.5	%
Current	802.11g QAM64 (@2.7-4.8Vbatt, -30C to +75C), Pout=15.5dBm min.		113	137	mA
Output Power <sup>4</sup>	802.11b (@3.6Vbatt, -30C to +75C, Min. Spectral Mask Margin 2.0dB)	20.5	21.5		dBm
Current	802.11b CCK (@2.7-4.8Vbatt, -30C to +75C), Pout=20.5dBm min.		200	220	mA
PA NF <sup>5</sup>	PA Noise Figure		7		dB
2 <sup>nd</sup> Harmonic <sup>5</sup>	Up to Pout=20.5dBm, (@2.7-4.8Vbatt, -30C to +75C)		-40	-30	dBc
3 <sup>rd</sup> Harmonic <sup>5</sup>	Up to Pout=20.5dBm, (@2.7-4.8Vbatt, -30C to +75C)		-50	-42	dBc
4 <sup>th</sup> Harmonic <sup>5</sup>	Up to Pout=20.5dBm, (@2.7-4.8Vbatt, -30C to +75C)		-62	-52	dBc
<b>Timing</b>					
PA Turn On Time <sup>5</sup>	To within 0.2dB steady state power		1.0		uSec
PA Turn Off Time <sup>5</sup>	To within -20dB w/r/t steady state "ON" output power		1.0		uSec
<b>Gain and Matching</b>					
PA ripple across channel <sup>5</sup>	PA ripple across 20MHz bandwidth		0.5		dB
Gain	Gain in 2.4GHz band	28	33.5	38.7	dB
WLAN TX Port Impedance			50		Ohm
<b>TX Rejection <sup>5</sup></b>					
869-894MHz	@ 50Ohm relative to transmit gain at 2.4-2.5GHz		75		dB
1570-1580MHz	@ 50Ohm relative to transmit gain at 2.4-2.5GHz		35		dB
1805-1880MHz	@ 50Ohm relative to transmit gain at 2.4-2.5GHz		28		dB
2110-2170MHz	@ 50Ohm relative to transmit gain at 2.4-2.5GHz		18		dB

Data Sheet: Subject to change without notice

For additional information and latest specifications, see our website: [www.triquint.com](http://www.triquint.com)



## 802.11b/g/n WLAN/BT Front-End Module

Parameter	Conditions	Min.	Typ/Nom	Max.	Units
<b>Power Detector</b>					
Frequency Range		2.4		2.5	GHz
Readout @20.5dBm			0.7	0.85	V
<b>WLAN Receive</b>					
Passband Insertion Loss	All other ports are terminated to their nominal impedances (-30C to +75C)		1.8	2.25	dB
Passband Ripple <sup>5</sup>	Across 20MHz BW, within Frequency Range, comply with Passband IL		0.05		dB PTP
Balanced Output Amplitude Imbalance <sup>5</sup>	In ISM band	-1		1	dB
Balanced Output Phase Imbalance <sup>5</sup>		-10		10	Deg
RX Port Impedance	Differential at the WLAN-RX port		100		Ohm
RX Port Return Loss <sup>5</sup>	All other ports are terminated in their nominal impedances	10	17		dB
<b>RX S21 <sup>5</sup></b>					
824-829MHz	Referenced to 50Ohms		-7	-5	dB
1710-1785MHz	Referenced to 50Ohms		-3	-2	dB
1920-1980MHz	Referenced to 50Ohms		-2	-1.5	dB
<b>BT RX/TX</b>					
Passband Insertion Loss			1.1	1.4	dB
Passband Ripple <sup>5</sup>	Comply with Passband Insertion Loss		0.05		dB
Maximum Port Power Level <sup>5</sup>	Due to Bluetooth Class 1.5		12	15	dBm
RX/TX Port Nominal Impedance			50		Ohm
RX/TX Port Return Loss <sup>5</sup>	In band, all other ports terminated in nominal impedance	10	14		

**Note 1:** Test Conditions:  $V_{B1}=3.6V$ ,  $V_{B2}=3.6V$ ,  $V_{B3}=3.6V$ .

**Note 2:** All limits are at +25°C case temperature unless otherwise specified.

**Note 3:** TriQuint Test Board.

**Note 4:** Additional degradation of 0.5dB at extreme conditions

**Note 5:** Guaranteed by design, not tested in production

**Data Sheet: Subject to change without notice**

For additional information and latest specifications, see our website: [www.triquint.com](http://www.triquint.com)



**802.11b/g/n WLAN/BT Front-End Module**

*Logic Truth Table*

	PAEN	TX SW	RX SW	BT SW	PABC
TX mode	1	1	0	0	Depends on WLAN Standard – See table below
RX mode	0	0	1	0	0 uA
RX-RX mode	0	0	1	1	0 uA
Calibration Mode	1	0	1	0	500uA
BT	0	0	0	1	0 uA
Shutdown Mode all "0"	0	0	0	0	0 uA
Shutdown Mode all "NC"	NC	NC	NC	NC	0 uA

Logic 0 = 0V - 0.01V  
Logic 1 = 1.58V – 2.0V

*PABC Table*

WLAN Standard	Modulation	PABC
IEEE 802.11b	1DSS – 1 Mbps	492uA
IEEE 802.11g	54OFDM – 54 Mbps	555uA
IEEE 802.11n	MCS7 – 65 Mbps	555uA

*Data Sheet: Subject to change without notice*

For additional information and latest specifications, see our website: [www.triquint.com](http://www.triquint.com)



**802.11b/g/n WLAN/BT Front-End Module**

*Pin Out and Assignments*

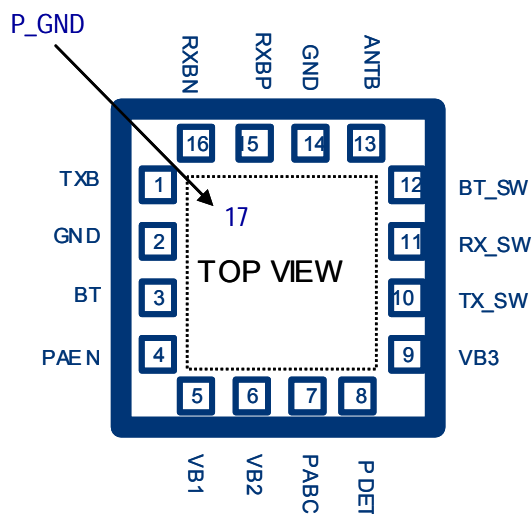

Pin	Symbol	Description
1	TXB	2.4GHz Transmit Input
2	GND	Ground
3	BT	Bluetooth port
4	PAEN	PA Enable Pin
5	VB1	Vbatt
6	VB2	Vbatt
7	PABC	PA Bias Control
8	PDET	Detector Voltage Output
9	VB3	Vbatt
10	TX_SW	TX Switch Control Voltage
11	RX_SW	RX Switch Control Voltage
12	BT_SW	BT Switch Control Voltage
13	ANTB	Antenna
14	GND	Ground
15	RXBp	RX differential Port Output +
16	RXBn	RX differential Port Output -
17	P_GND	Package Common Ground

*Data Sheet: Subject to change without notice*

For additional information and latest specifications, see our website: [www.triquint.com](http://www.triquint.com)



**802.11b/g/n WLAN/BT Front-End Module**

*DC Blocking*

Pin	DC block/path
TXB	DC blocked internally
BT	DC blocked internally
ANTB	DC blocked internally
RXBp	Internal DC path to ground, Internal DC path to RXBn
RXBn	Internal DC path to ground, Internal DC path to RXBp



**802.11b/g/n WLAN/BT Front-End Module**

*Typical Application/Test Circuit*

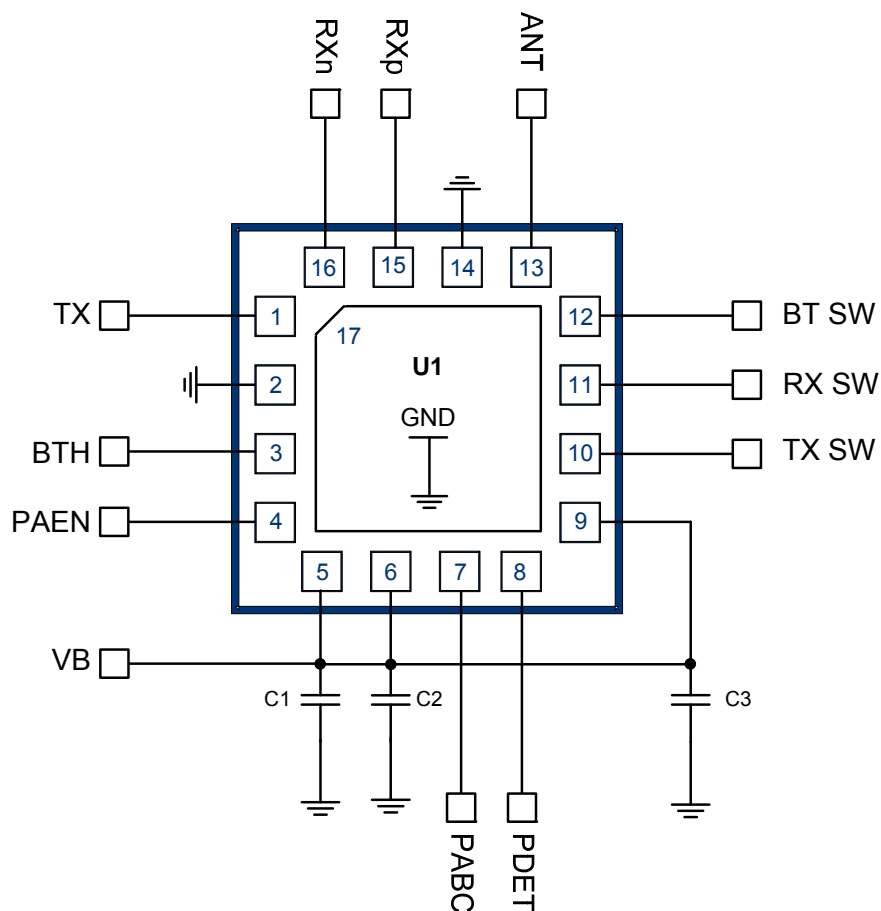

Component	Reference Designator	Value	Part Number
Power Amplifier Module	U1		TQM679002A
Capacitor	C1	0.22uF	
Capacitor	C2	0.1uF	
Capacitor	C3	1uF	

*Data Sheet: Subject to change without notice*

For additional information and latest specifications, see our website: [www.triquint.com](http://www.triquint.com)





**802.11b/g/n WLAN/BT Front-End Module**

*Applications Information: Power Up/Down Sequence*

Shutdown Mode to TX Mode Power-Up Sequence

Sequence	Pin	Description
1	VB1, VB2, VB3 <sup>1</sup>	Apply Battery Voltage
2	TX SW, RX SW, BT SW, PABC	Apply RF switch control signals and PABC See <b>PABC Table</b> for Reference Current <sup>2</sup>
3	PAEN	Enable PA
4	RF	Apply RF

TX Mode to Shutdown Mode Power-down Sequence

Sequence	Pin	Description
1	RF	Remove RF
2	PAEN	Disable PA
3	TX SW, RX SW, BT SW, PABC	Apply RF switch control signals and Remove Reference Current
4	VB1, VB2, VB3	Remove Battery Voltage

Notes:

- 1) VB1, VB2 and VB3 are jumpered with 0Ω resistors on the TQS evaluation board.
- 2) The voltage on the Pabc pin varies so TQS would not recommend applying a fixed DC voltage to this pin with a DC voltage supply. A current source or an adjustable voltage supply can be used instead.

*Data Sheet: Subject to change without notice*

For additional information and latest specifications, see our website: [www.triquint.com](http://www.triquint.com)



**802.11b/g/n WLAN/BT Front-End Module**

*PCB Footprint (Notes: Primary dimensions are in millimeters alternate dimensions in brackets are in inches)*

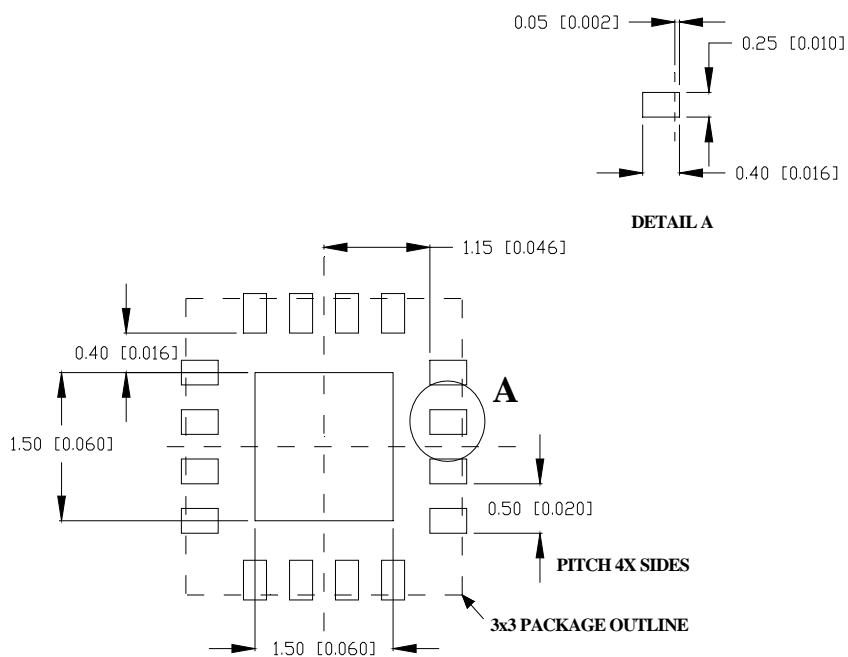

*Data Sheet: Subject to change without notice*

For additional information and latest specifications, see our website: [www.triquint.com](http://www.triquint.com)



**802.11b/g/n WLAN/BT Front-End Module**

**Packaging and Ordering Information**

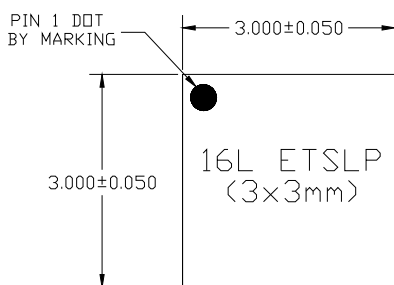

TOP VIEW

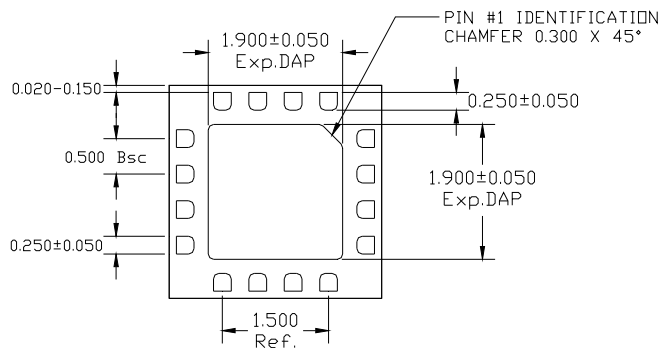

BOTTOM VIEW

A	MAX.	ETSLP 0.500
	NOM.	0.450
	MIN.	0.400

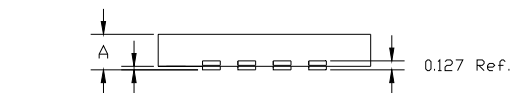

SIDE VIEW



**802.11b/g/n WLAN/BT Front-End Module**

*Part Marking*

PIN 1 



Line 1: 6792A = Product code.

Line 2: YYWW - Year and workweek

Line 3: XXXX - TriQuint assembly lot number

*Data Sheet: Subject to change without notice*

For additional information and latest specifications, see our website: [www.triquint.com](http://www.triquint.com)



**802.11b/g/n WLAN/BT Front-End Module**

*Tape and Reel Information*

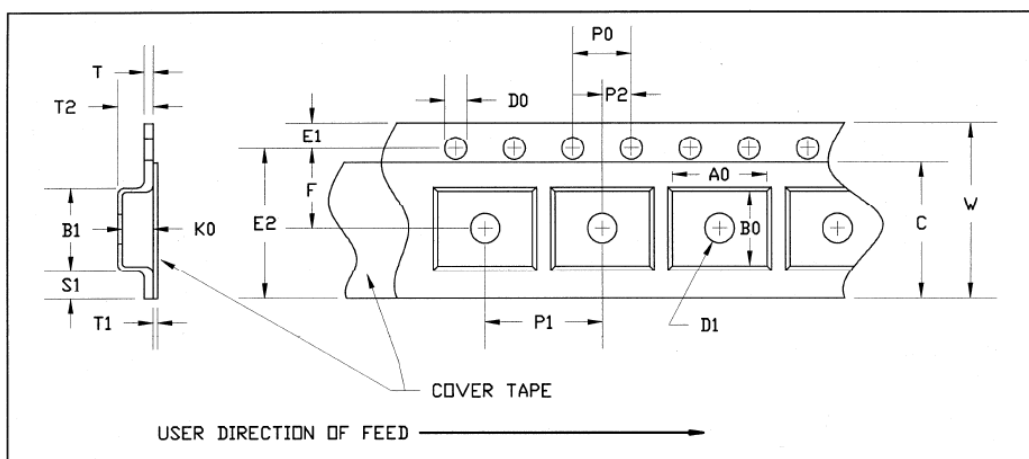

3x3 16 ETSLP and 3x3 16 T/SLP 8mm WIDE CARRIER AND COVER TAPE DIMENSIONS

PART	FEATURE	SYMBOL	SIZE (in)	SIZE (mm)
CAVITY	LENGTH	A0	0.134	3.40
	WIDTH	B0	0.126	3.20
	DEPTH	K0	0.055	1.40
	PITCH	P1	0.157	4.00
DISTANCE BETWEEN CENTERLINE	CAVITY TO PERFORATION LENGTH DIRECTION	P2	0.079	2.00
	CAVITY TO PERFORATION WIDTH DIRECTION	F	0.138	3.50
COVER TAPE	WIDTH	C	0.213	5.40
CARRIER TAPE	WIDTH	W	0.315	8.00

*Data Sheet: Subject to change without notice*

For additional information and latest specifications, see our website: [www.triquint.com](http://www.triquint.com)



**802.11b/g/n WLAN/BT Front-End Module**

*Reel Physical Dimensions*

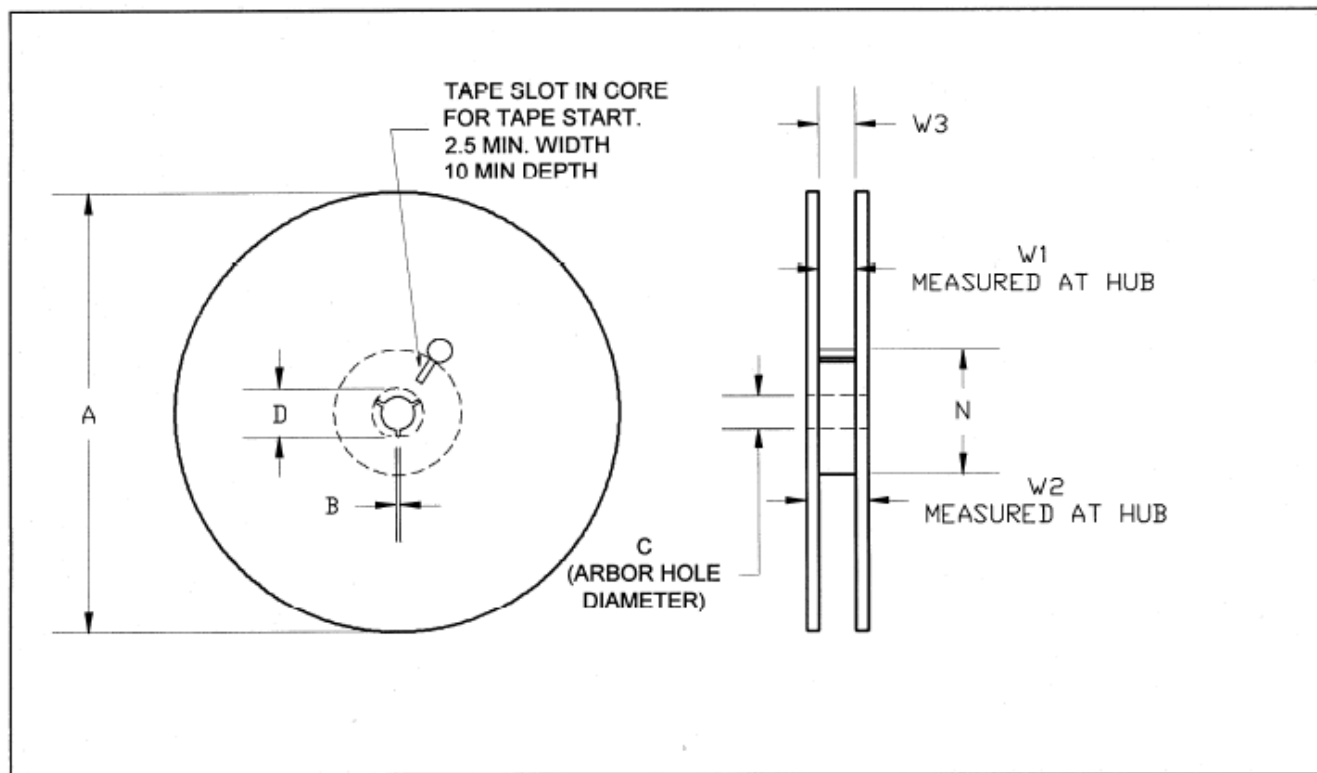

**Reel Dimensions for 8mm Carrier Tape – 7" Reel**

SOT 23-6 & 8, HP VFQFP-N 2X2, 3X3, MW-6, SCT-598, SC 70-4 & 6, SLIM 7, 13 & 17, VQFN 6 3x2 and ETSLP-6 and 1.5X1.5 ETSLP and 3x3 16 ETSLP and 3x3 16 T/SLP			7" Reel	
PART	FEATURE	SYMBOL	SIZE (in)	SIZE (mm)
FLANGE	DIAMETER	A	6.969	177.0
	THICKNESS	W2	0.559	14.2
	SPACE BETWEEN FLANGE	W1	0.346	8.8
HUB	OUTER DIAMETER	N	4.016	102.0
	ARBOR HOLE DIAMETER	C	0.512	13.0
	KEY SLIT WIDTH	B	0.079	2.0
	KEY SLIT DIAMETER	D	0.787	20.0

*Data Sheet: Subject to change without notice*

For additional information and latest specifications, see our website: [www.triquint.com](http://www.triquint.com)



**802.11b/g/n WLAN/BT Front-End Module**

*Tape Length and Label Placement*

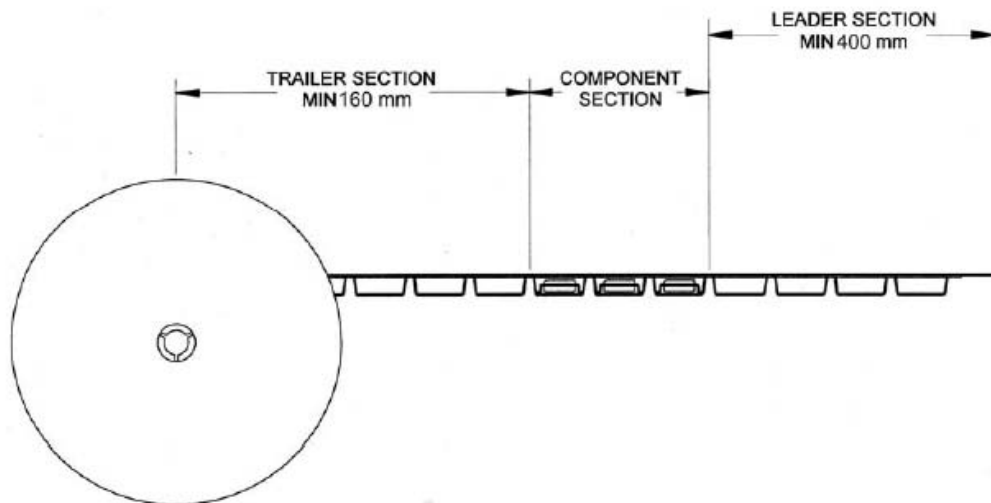

Empty part cavities at the trailing and leading ends are sealed with cover tape.  
See EIA 481-1-A

LABEL PLACEMENT

Labels are placed on the flange opposite to the sprockets in the carrier tape.

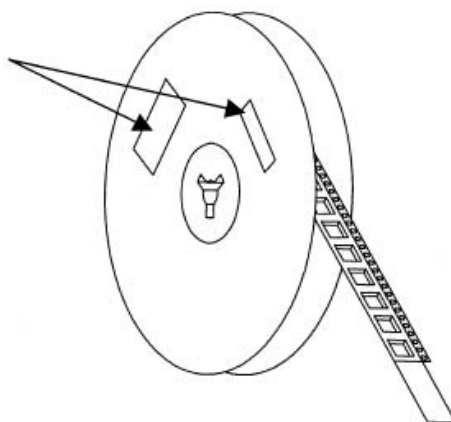

*Data Sheet: Subject to change without notice*

For additional information and latest specifications, see our website: [www.triquint.com](http://www.triquint.com)



**802.11b/g/n WLAN/BT Front-End Module**

TAPE PEEL STRENGTH, PULL VELOCITY, AND PEEL ANGLE

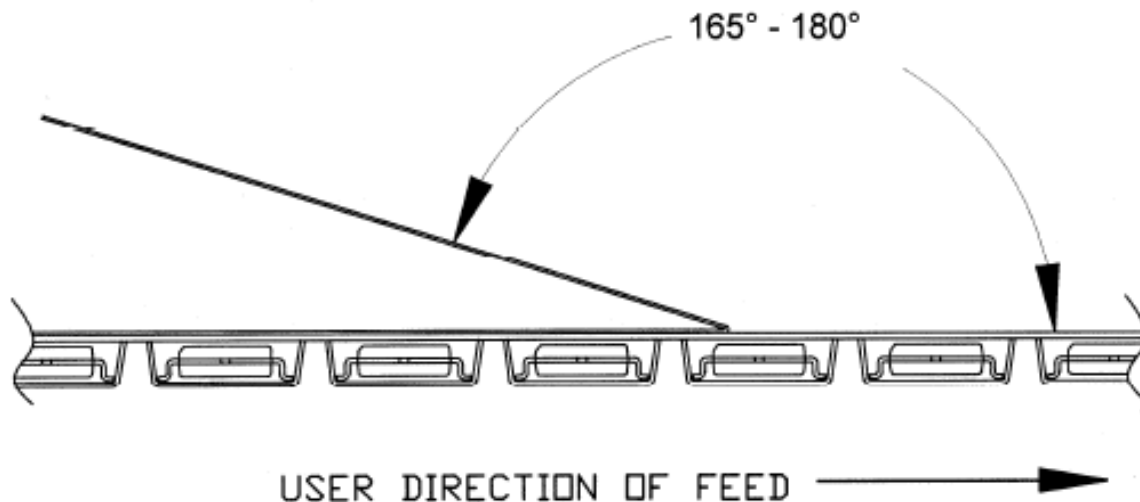

Peel strength 0.1 N to 1.0 N for 8 mm Carrier Tape  
Peel strength 0.1 N to 1.3 N for 12 mm Carrier Tape  
Pull velocity 300 +/- 10 mm/min

Data Sheet: Subject to change without notice

For additional information and latest specifications, see our website: [www.triquint.com](http://www.triquint.com)

Revision C, April 8, 2010





**802.11b/g/n WLAN/BT Front-End Module**

This part is compliant with RoHS directive (Restrictions on the Use of Certain Hazardous Substances in Electrical and Electronic Equipment).

The part is rated Moisture Sensitivity Level 1 at 260°C per JEDEC standard IPC/JEDEC J-STD-020.

**Additional Information**<sup>1</sup>

---

<sup>1</sup> For latest specifications, additional product information, worldwide sales and distribution locations, and information about TriQuint:

Web: [www.triquint.com](http://www.triquint.com)

Tel: (503) 615-9000

The information provided herein is believed to be reliable; TriQuint assumes no liability for inaccuracies or omissions. TriQuint assumes no responsibility for the use of this information, and all such information shall be entirely at the user's own risk. Prices and specifications are subject to change without notice. No patent rights or licenses to any of the circuits described herein are implied or granted to any third party.

TriQuint does not authorize or warrant any TriQuint product for use in life-support devices and/or systems.

Copyright © 2010 TriQuint Semiconductor, Inc. All rights reserved. 2010

**Data Sheet: Subject to change without notice**

For additional information and latest specifications, see our website: [www.triquint.com](http://www.triquint.com)

